

KW-FF1A[AC], KW-FF1B[Battery]

FILLET & BUTT WELDER, FLOOR & WALL TRAVEL, ONE TORCH, STITCH & CONTINUOUS

APPEARANCE

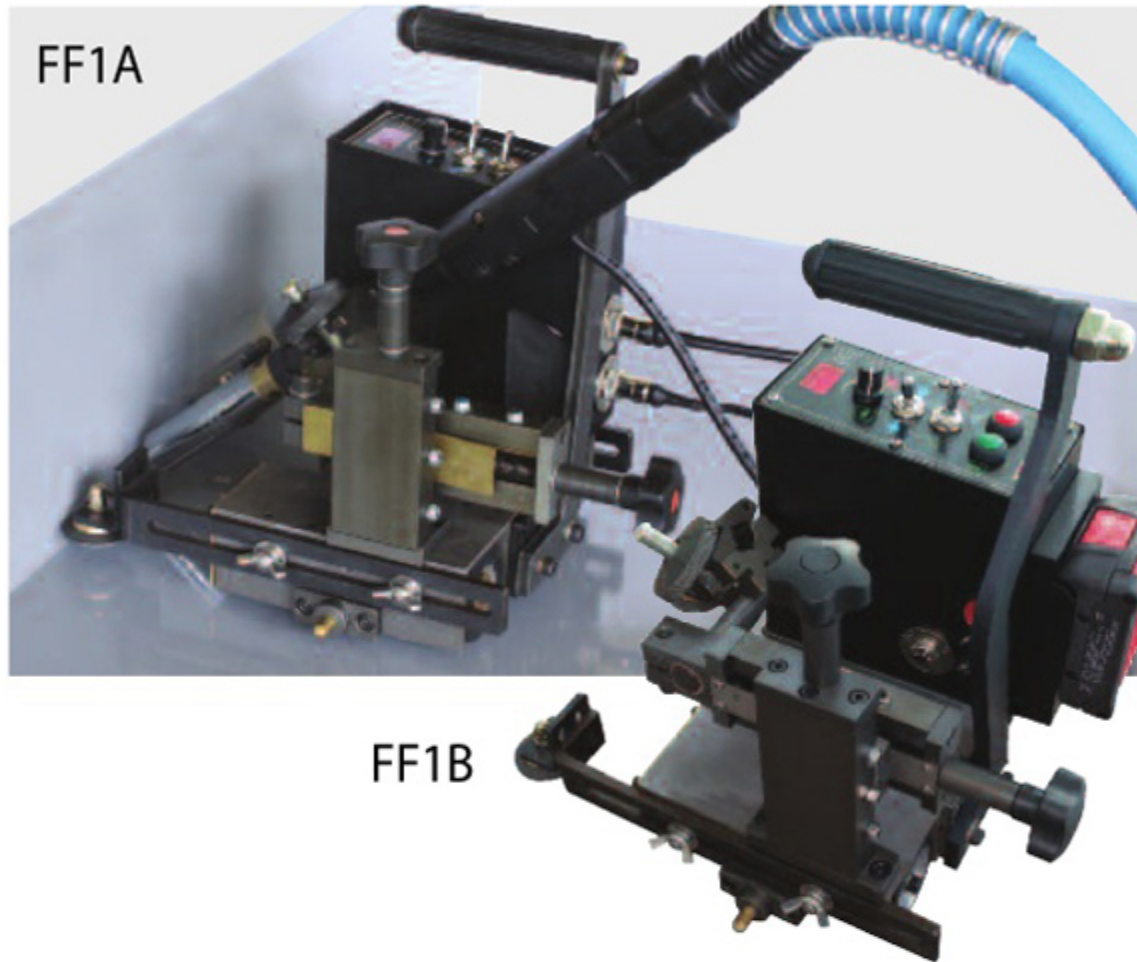

FEATURES

- For Single torch floor wall traveling for Fillet & Butt welding
- Stitch & continuous welding
- X-Y slider helps setting torch widely
- Both mechanized & manual torches useful.
- Max pulling power of magnet 20kgf and travels Max. 30°climbable.
- Limit switches stop the carriage when welding finished.
- Crater filling time at the beginning and ending of the welding can be controlled for 0~3 seconds.
- Travel speed in cm/min or inch/min programmable.
- Battery power, 18Vdc 4.0Ah lithium-ion, 10-12Hrs use

FILLET WELDING

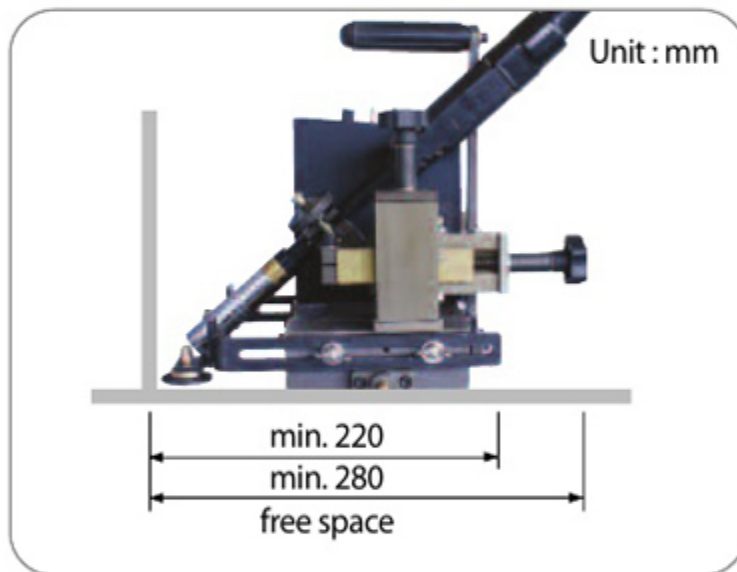

BUTT WELDING

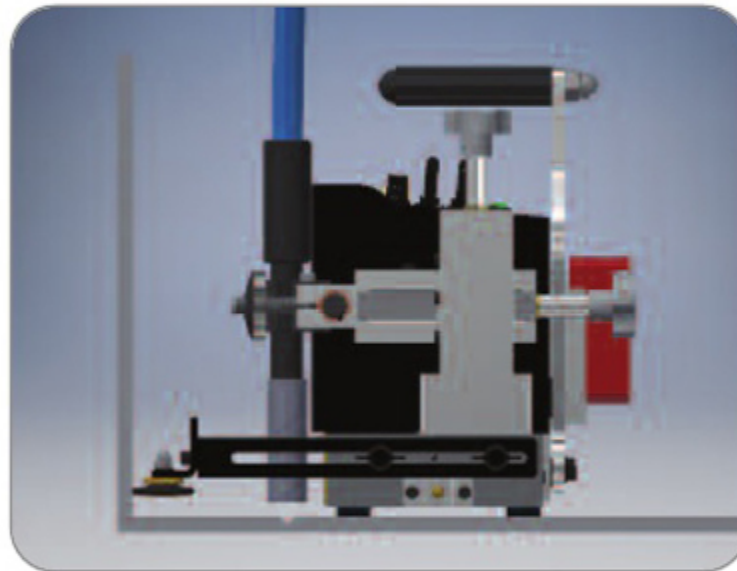

RADIUS

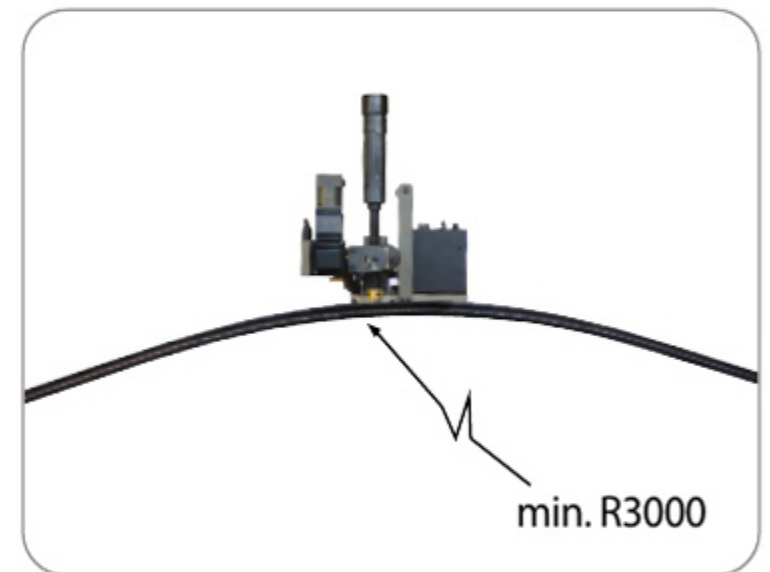

MAJOR PARTS	DESCRIPTIONS	SPECIFICATIONS
General	Size in mm(WHL), Weight	Carriage: 260 x 270 x 300, 6.0Kg Packing: 480 x 350 x 350, 10.0kg
	Input Power	AC 100-240V, 50-60Hz, 1Phase Lithium-ion Battery 18Vdc 4.0Ah 10-12Hrs use
Traveling Unit	Motor	24Vdc, 10W, 5,000rpm
	Reducer	1:624 (gear ratio 1:1)
	Speed	0~860mm/min
	Power transmission	4 wheels chain driven
	Magnet location	Bottom on the carriage
X-Y slide	X-slide stroke	0~50mm
	Y-slide stroke	0~50mm
	Torch adjustable angle	0-90°